

Air Knight[®] WITH IPG

IONIZED PARTICLE GATHERING

AIR PURIFICATION SYSTEM

SUBMITTAL

The Air Knight[®] Air Purification System is designed to be installed into an existing HVAC system and provide virtually maintenance free air purification. Please read and follow all service procedures outlined in the manual.

Dimensions:

See Fig.1

Weight:

Approx. 3 lbs.

Warranty:

7-yr ballast. 4-yr cell. 2-yr bulb.

Fig. 1 Dimensions of Air Knight unit.

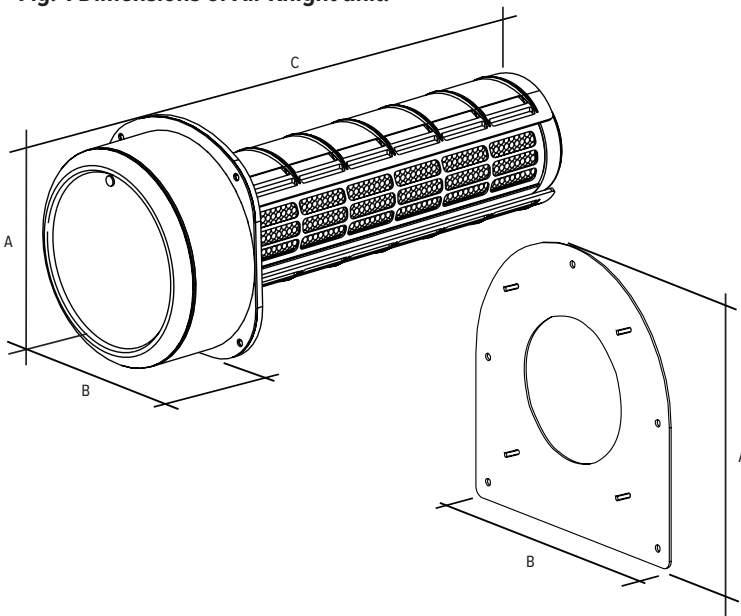

MODEL	DIM. A	DIM. B	DIM. C
7" Unit	6.5"	6"	9.9"
14" Unit	6.5"	6"	14.5"
M. Plate	7.875"	7.875"	

Specifications subject to change without notice.

EPA Establishment No.: 73316-TX-1



Electrical:

The unit uses an electronic power module. The device must be installed in compliance with all national and local electrical and mechanical codes. Always use a dedicated 40Va transformer. If connecting a second air purifier or UV light to auxiliary power port, use 75Va transformer.

Power Ratings: 24VAC 50/60 Hz.

Output: 19.2 Watts

Listings:

UL 2998 validated no ozone.

Meets California ozone emissions limit: CARB certified.

As additional safety support, the Air Knight product-line has received the following universally accepted UL certified listings; UL 1598, UL 1995, UL 867, CSA C22.2 No. 250.0 and CSA C22.2 No. 236.

Temperature:

45 F - 150 F (Outside of duct).

Airflow:

7" Unit - Up to 2000 CFM.

14" Unit - Up to 3000 CFM.

Air flow specification subject to pollutant levels.

Date: _____

Engineer: _____

Job Name: _____

Contractor: _____

Location: _____

Submitted By: _____